

MEDENUS



Gas Pressure Regulation



Safety Shut-Off Valve S 100

Product information



EN

Table of contents

Application, characteristics, technical data	4
Application	4
Characteristics	4
Type of model / Options	4
Technical data	5
Structure and function	6
Installation example	6
Sectional view	7
K_G^* value	8
SSV setpoint spring table - control device	9
Dimensions, connection and weight	10
Dimensional drawing	10
Dimensions and weight	11
Connection of the measuring lines and breather lines	11
Types of models / Options	12
Design	13
Properties of gases	13
Order data	14
Notes	15
Contact	16



ATTENTION

Observe the following publications in relation to installation, start-up and maintenance:
 DVGW - work sheets G 491 and G 600
 Operating and Maintenance Instructions S100

List of abbreviations and formula symbols

AC	Accuracy class	$p_{ds\ o}$	Upper SSV response pressure	$W_{ds\ o}$	Upper spring adjustment range (SSV)
AG_o	Upper response pressure group	$p_{ds\ u}$	Lower SSV response pressure	$W_{ds\ u}$	Lower spring adjustment range (SSV)
AG_u	Lower response pressure group	$p_{f,max}$	Maximum closing pressure	Δp	Pressure difference from inlet pressure to outlet pressure
BV	Breather valve	PS	Maximum allowable pressure	Δp_{wo}	Min. re-engagement difference between upper response pressure and normal operating pressure
GPR	Gas pressure regulator	p_u	Inlet pressure	Δp_{wu}	Min. re-engagement difference between lower response pressure and normal operating pressure
HDS	High-pressure spindle	Q_n	Standard volumetric flow rate	ρ_n	Gas density
K_G	Valve flow rate coefficient	RE	Diaphragm assembly		
p	Pressure	RSD2	Throttle valve		
p_d	Outlet pressure	SSV	Safety shut-off valve		
p_{df}	SRV closing pressure	SRV	Safety relief valve		
p_{do}	SRV opening pressure	SG	Closing pressure group		
p_{ds}	Setpoint of the response pressure	t_{Gas}	Gas inlet temperature		
		VS	Valve seat		
		w_d	Outlet gas velocity		
		w_u	Inlet gas velocity		

*) K_G value for natural gas

Application, characteristics, technical data

Application

Safety shut-off valve (SSV), direct-acting (operating without auxiliary power), for systems acc. to DVGW Code of Practice G 491 (A) and G 600 (A) (TRGI)

Can be used as an equipment component on gas consumption facilities as defined in Regulation (EU) 2016/426.

Can be used for the gases defined in DVGW Code of Practice G 260 / G 262 and neutral non-aggressive gases. (other gases on request)

Characteristics

- Integral pressure-tight version (IS)
- High flow rate capacity
- Open-air model

Type of models / Options (see page 12)

- With BV breather valve
- With electric position indicator SSV "Closed" via inductive proximity initiator or via Reed contact
- With SSV electromagnetic remote release when power is applied or in case of power failure
- With SSV manual release
- Oxygen model
- Hydrogen version
- Coating with epoxy resin in RAL colors

Response pressure groups

Upper response pressure group AG_o in command area w_{dso}	AG_o
50 mbar to 100 mbar	10
> 100 mbar to 500 mbar	5
> 500 mbar	2.5

Lower response pressure AG_u in command area w_{dsu}	AG_u
10 mbar to 30 mbar	20
> 30 mbar to 50 mbar	10
> 50 mbar	5

Technical data

Type	S 100
Model	Integral pressure-tight (IS)
Max. allowable pressure PS	8 bar
Max. inlet pressure $p_{u,max}$	8 bar
Nominal width	DN 25, DN 40, DN 50, DN 65, DN 80, DN 100, DN 125, DN 150, DN 200
Connection type	DIN EN 1092 PN 16 flanges ASME - B16.5 flanges Class 150 RF
Material	
Housing / actuator housing/ control device housing	Al cast alloy
Corrosivity category	DIN EN ISO 12944-2
C1 to C5-I	without additional coatings
C5-M	an epoxy resin coating is recommended (see page10)
Temperature range, Class 2 (operating/ambient temperature)	-20°C to +60°C
Function, strength, and tightness to CE mark acc. to PED/ PIN number	DIN EN 14382 CE-0085-AQ0880
Ex protection	The mechanical parts of the device do not have any potential ignition sources of their own and therefore do not fall within the scope of ATEX 95 (94/9/EC). Electrical components fitted to the device comply with the ATEX requirements.

Preferred installation position

The gas pressure regulators S100 shall be installed in the pipeline preferably in horizontal position. For all nominal widths, the direction of flow is indicated by an arrow on the housing.

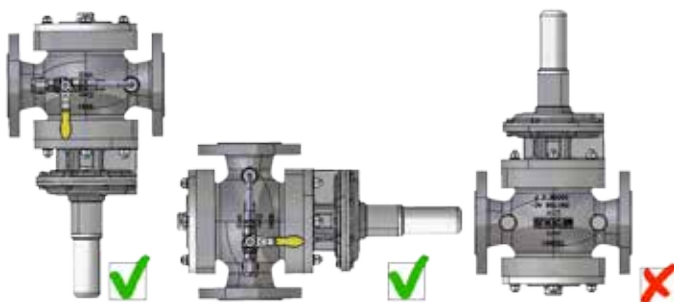

Overhead installation position
only after consultation
with Medenus GmbH

Note: Observe the following documents in relation to installation, start-up, and maintenance:

- DVGW - work sheets G 491 and G 600
- Operating and Maintenance Instructions S100

Structure and function

The safety shut-off valve S 100 shuts off the gas flow when the outlet pressure in the regulating section exceeds or falls below a certain response pressure. For this purpose the outlet pressure is monitored by the SSV control device via a separate measurement line.

As a function of the change in pressure, the diaphragm in the control device is raised or lowered. When the outlet pressure in the regulating section falls below the lower switch-off point or exceeds the upper switch-off point, the switch socket connected to the SSV diaphragm will move to the corresponding disengaging position, the balls of the engaging mechanism will release the SSV screw spindle and the closing spring will press the SSV valve plate against the valve seat. The SSV actuator shuts off the gas flow gas-tight.

The SSV can only be opened by hand and engaged in the open position. To do so, the outlet pressure at the measuring point must be lowered below the upper response pressure or raised above the lower response pressure by at least the re-engaging differential amount (Δp).

The SSV can, except where otherwise stipulated in specific national legislation, be used in either functional class A (with diaphragm rupture protection) or B (without diaphragm rupture protection).

There is also the option of using a remote display for the SSV position "CLOSED" and a manual and remote release when power is applied or in case of power failure.

Installation example

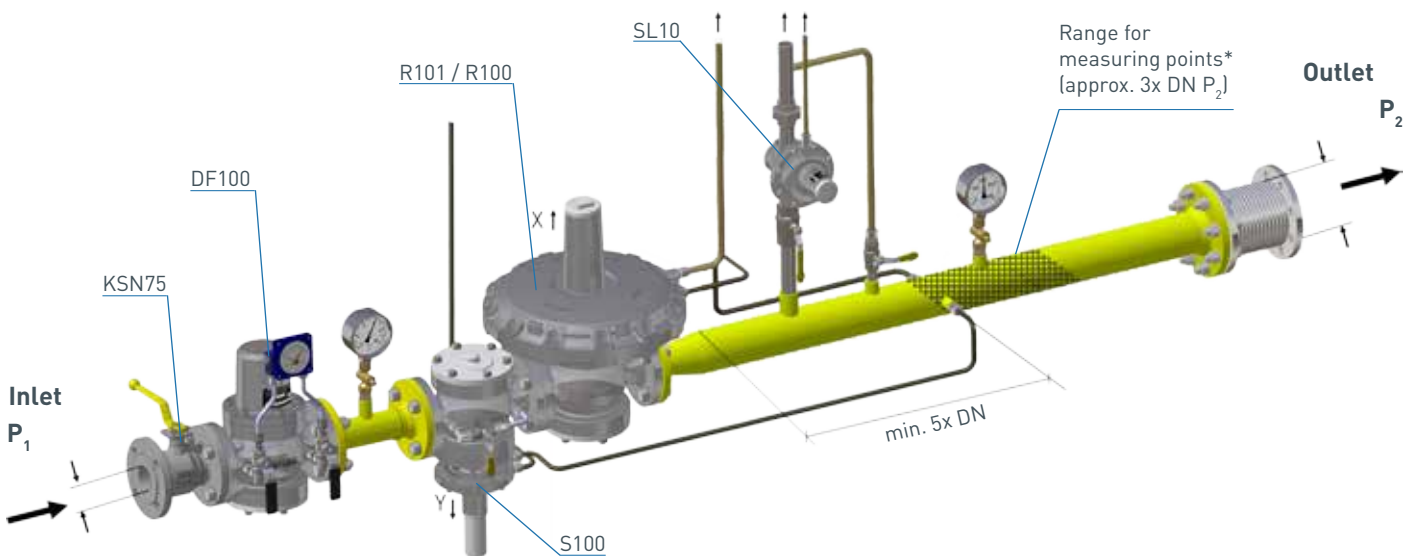

*) Recommended max. velocity at the measurement line port 25 m/s

Sectional view

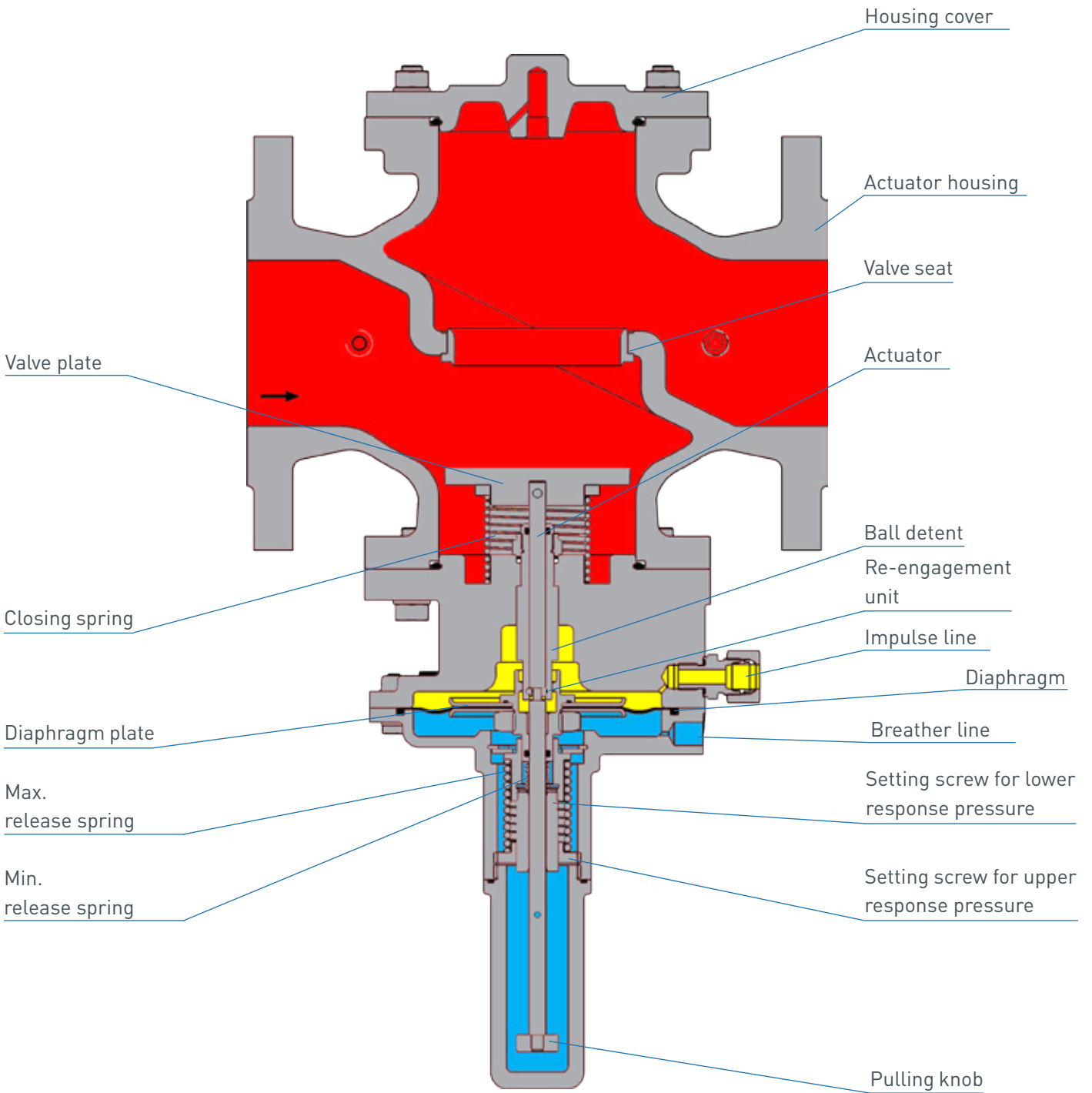

K_G value

(K_G value for natural gas: $\rho_n = 0.83 \text{ kg/m}^3$, $t_u = 15^\circ\text{C}$)

Nominal width Valve seat \emptyset	DN	DN	DN	DN	DN	DN	DN	DN	DN
	25	40	50	65	80	100	125	150	200
32.5 mm	450	550							
52.5 mm			1350	1650					
80.0 mm					3300	3900	4500		
125.0 mm								8000	
160.0 mm									14,000
Connection type	DIN EN 1092 - PN16								

SSV setpoint spring table - control device

S100: DN 25 - 125													
small ball lock													
MD**				MD-R				HD					
to W_{ds_o} 300 mbar				to W_{ds_o} 3500 mbar				to W_{ds_o} 8000 mbar					
Spring data		Lower response pressure		Upper response pressure		Lower response pressure		Upper response pressure		Lower response pressure		Upper response pressure	
Spring no.	Color [RAL]	W_{ds_u} [mbar]	Δp_{wu} [mbar]	w_{dso} [mbar]	Δp_{wo} [mbar]	W_{ds_u} [mbar]	Δp_{wu} [mbar]	w_{dso} [mbar]	Δp_{wo} [mbar]	W_{ds_u} [mbar]	Δp_{wu} [mbar]	w_{dso} [mbar]	Δp_{wo} [mbar]
FE 900	1028	1 - 8	20			35 - 50	50			120 - 180	500		
FE 901 VA	2002	6 - 17	20			50 - 80*	50			150 - 280*	500		
FE 902 VA	6010	12 - 24*	20			70 - 105	50			280 - 480	500		
FE 903	5015	22 - 40	20			100 - 140	50			330 - 500	500		
FE 904 VA	9005	30 - 50	20			110 - 160	50			400 - 550	500		
FE 905 VA	9010	45 - 70	20			150 - 205	50			550 - 800	500		
FE 906	4002	65 - 100	20			200 - 300	50			800 - 1200	500		
FD 910	1028			20 - 40	20			90 - 125	50				
FD 911	2002			35 - 70	20			120 - 210	50				
FD 912	6010			65 - 110	20			200 - 330	50				
FD 913	5015			100 - 160	20			285 - 460	50				
FD 914	9005			150 - 235	20			450 - 680	50				
FD 915	9010			225 - 300	20			640 - 1040	50			2200 - 4000	300
FD 916	3030							1030 - 1480	50			3400 - 4750	300
FD 917	5010							1450 - 2200	50			4700 - 7400	300
FD 918	9006							1900 - 3500	50			7200 - 8000	300
FD 919	4002												

S100: DN 150 - 200													
large ball lock													
MD**				MD-R				HD					
to W_{ds_o} 300 mbar				to W_{ds_o} 3500 mbar				to W_{ds_o} 8000 mbar					
Spring data		Lower response pressure		Upper response pressure		Lower response pressure		Upper response pressure		Lower response pressure		Upper response pressure	
Spring no.	Color [RAL]	W_{ds_u} [mbar]	Δp_{wu} [mbar]	w_{dso} [mbar]	Δp_{wo} [mbar]	W_{ds_u} [mbar]	Δp_{wu} [mbar]	w_{dso} [mbar]	Δp_{wo} [mbar]	W_{ds_u} [mbar]	Δp_{wu} [mbar]	w_{dso} [mbar]	Δp_{wo} [mbar]
FM 400	1028	10 - 40*	20			20 - 180*	50			0 - 250	500		
FM 402	6010	35 - 115	20			155 - 380	50			150 - 1000*	500		
FM 404	9005	60 - 245	20			200 - 950	50			650 - 2050	500		
FL 412	6010			40 - 180	20			145 - 670	50			380 - 1400	300
FL 413	5015			70 - 300	20			270 - 1230	50			800 - 2800	300
FL 415	9010							1200 - 3500	50			3200 - 5500	300
FL 417	4010											4500 - 8000	300

*) Standard spring

**) If the control device is set up for simultaneous monitoring of upper and lower response pressures, the difference between the setpoints for the upper and lower response pressures (p_{dso} and p_{dsu}) should be at least 10% greater than the total of values given for Δp_{wo} and Δp_{wu} .

Dimensions, connection and weight

Dimensional drawing

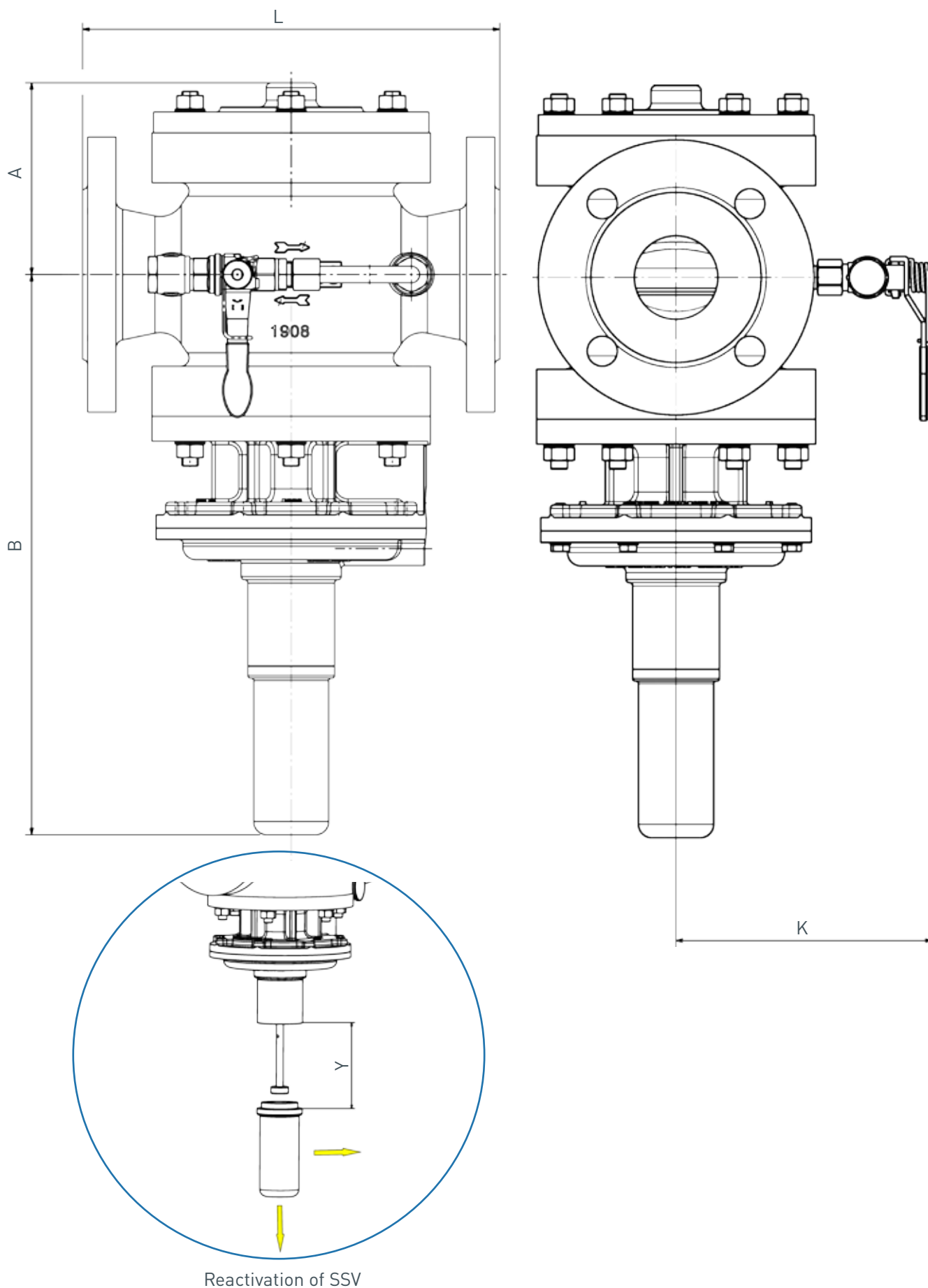

Dimensions and weight

Dimensions	Nominal width	DN 25	DN 40	DN 50	DN 65	DN 80	DN 100	DN 125	DN 150	DN 200
	A [mm]		105	98	115	116	139	150	150	195
B [mm]		286	314	336	342	360	360	371	371	475
B [mm] model with HD SSV [mm]		+10	+10	+10	+10	+10	+10	+10	+23	+23
L [mm]		160	160	250	220	280	300	260	380	420
K [mm]		157.5	175	153	160	165	177.5	190	209	233
Y [mm]		100	100	100	100	100	100	100	150	150
Weight [kg]		3.5	5.0	8.5	7.0	13.0	15.0	32.0	32.0	49.0
Connection	DIN EN 1092 - PN16									

Connection of the measuring lines and breather lines

Nominal width	Version	Bore Ø		Measurement line	Breather line
		Measurement line	Breather line		
DN 025 DN 040	MD	2	2	Connection* for: tube 12 x 1.5 (thread G 1/4)	
	MD-R	2	3		
	HD	2	2		
DN 050	MD	2	2		
	MD-R	2	3		
	HD	2	2		
DN 065	MD	3,5	2		
	MD-R	3,5	3		
	HD	3,5	2		
DN 080 DN 100 DN 125	MD	2	2		
	MD-R	2	3		
	HD	2	2		
DN 150	MD	4	2	Connection* for: tube 12 x 1.5 (thread G 3/8)	
	MD-R	4	2		
	HD	4	2		
DN 200	MD	4	2		
	MD-R	4	2		
	HD	4	2		

Types of models / Options

BV breather valve

The BV breather valve is used as for securing the installation room against inadmissible escape of gas from diaphragm comparator compartments of safety shut-off valves. In case of a defect, the impermissible escape of gas into the surrounding atmosphere is limited to a maximum of 30l/h (air).

It also serves as a substitute for an expensive and complex installation of breather lines.



BV breather valve

(Option not available for hydrogen version H₂)

Reed contact / inductive transmitter

Reed contacts and inductive transmitters are used to monitor the position (closed or open position) of the safety shut-off valve via remote display.



Signal transmitter



Inductive transmitter

SSV manual and remote release

The direct-acting safety solenoid valve is used as electromagnetic remote release for closing the safety shut-off valve when power is applied or in case of power failure.



Epoxy resin coating in RAL colors

To protect the gas pressure regulator from external influences, starting from a corrosivity category C5-M we recommend an epoxy resin coating.



Types of models

Oxygen model O₂

Hydrogen version H₂ (with helium leak test)

The Medenus gas pressure regulators are suitable for use with hydrogen as a medium up to a proportion of 100%. Further information can be found in the special edition (10/2019) of gwf Gas+Energie and on our homepage at (www.medenus.de)



Design

Device selection

Selection of the SSVs from the SSV control device table (page 7)

Note: Recommended upper SSV response pressure $p_{ds\ o} < 500 \text{ mbar} + p_{ds}$

Note: When selecting springs, AG_o and AG_u must be observed. The possible minimum and maximum response pressures are calculated as follows:

$$p_{dso\ min/max} = p_{ds\ o} \cdot (1 \pm AG_o / 100)$$

$$p_{dsu\ min/max} = p_{ds\ u} \cdot (1 \pm AG_u / 100)$$

Checking the gas velocities

$$w = 380 \cdot Q_n / (DN^2 \cdot p_{abs})$$

Note: The factor 380 refers to an operating gas temperature from approx. 15°C to 20°C. For other temperatures, the velocity must be corrected as follows: $w_{corr} = w \cdot (t_{gas} + 273.15) / 290$

Recommended max. gas velocity at the inlet flange:
50 - 70 m/s Lower value for redirections upstream of the SSV

Example:

MDR with FD 914 (440-770 mbar)
 AG_o 10
set to $p_{ds\ o} = 700 \text{ mbar}$
and FE 904 (110-150 mbar) AG_u 5
set to $p_{ds\ u} = 130 \text{ mbar}$

$$p_{dso\ max} = 700 \cdot (1 + 10 / 100) = 770 \text{ mbar}$$

$$p_{dso\ min} = 700 \cdot (1 - 10 / 100) = 630 \text{ mbar}$$

$$p_{dsu\ max} = 130 \cdot (1 + 5 / 100) = 136.5 \text{ mbar}$$

$$p_{dsu\ min} = 130 \cdot (1 - 5 / 100) = 123.5 \text{ mbar}$$

Inlet and outlet nominal width of the pipeline according to the selected device: 80 mm

Selected widening of outlet pipeline: 200 mm

$$w_u = 380 \cdot 2500 / (80^2 \cdot 6) = 24.7 \text{ m/s}$$

The device selected in the example of nominal width DN 80 can be operated under these conditions.

Determining the upper response pressure

Outlet pressure P_d (mbar)	Upper response pressure W_{dso}
≤ 200	$P_d + 100 \text{ mbar}$
$> 200 - \leq 800$	$P_d \times 1.5$
$> 800 - \leq 1600$	$P_d \times 1.3$
> 1600	$P_d + 500 \text{ mbar}$

Pressure loss formula

Calculation pressure absolute ($p_u + 1 \text{ bar}$) = $p_{u,abs}$

$$\Delta p = \left(\frac{Q_n}{K_G} \right)^2 \times \frac{1000}{p_{u,abs}}$$

Properties of gases

- for natural gas ($\rho_n = 0.83 \text{ kg/m}^3$; $t = 15^\circ\text{C}$)
- f - natural gas conversion factor- L

Gas	f	Hs,n [kWh/m ³]	Gas	f	Hs,n [kWh/m ³]
Acetylene	0.84	16.25	Sewage gas	0.84	
Ammonia	1.04	4.83	Carbon monoxide	0.81	3.51
Butane	0.55	37.23	Carbon dioxide	0.65	-
Chlorine	0.51	-	Air	0.80	-
Landfill gas	approx. 0.80		Methane	1.08	11.06
Natural gas L	1.00	9.77	Propane	0.64	28.03
Natural gas H	1.03	11.45	Oxygen	0.76	-
Ethane	0.78	19.55	Sulphur dioxide	0.53	-
Ethylene	0.97	16.516	Nitrogen	0.81	-
Mine gas (30% CH ₄)		0.86	Hydrogen	3.04	13.43
Helium	2.15	-			

Order data

Example:

Safety shut-off valve: S100/050/MD-R/left/BV/N/H/WAZ/So

Order selection	Order code:	S100	050	-	MD-R	-	left	BV	N	H	WAZ	So
Designation												
Type												
S100	S100	S100										
DN - Nominal width	Table p. 8		050									
Flange model												
PN 16	-			-								
Class 150	C											
SSV												
with control device MD	MD											
with control device MD-R	MD-R				MD-R							
SSV functional class												
A	-					-						
B	B											
Direction of flow												
Right (from left to right)	-											
Left (from right to left)	left						left					
SSV valve accessories	Fig. p. 12											
without SSV valve accessories	-											
Breather valve	BV							BV				
Electrical position indicator, SSV "Closed"	Fig. p. 12											
without electrical position indicator	-											
with ... , via proximity switch	N								N			
with ... , via Reed contact	R											
SSV release	Fig. p. 12											
without release	-											
with manual release	H									H		
with electromagnetic remote release, when power is supplied	SG											
with electromagnetic remote release, in case of power failure	SA											
Acceptance test certificate to EN 10204/3.1												
without acceptance test certificate	-											
with acceptance test certificate	WAZ										WAZ	
Special model	So*											So
- Coating with epoxy resin in RAL colors Oxygen model												

In every selection group, only one option can be selected in each case.

Contact



Management
ALEXANDER CHRISTIANI

Phone: +49 (0) 2761 / 82788-18
Mail: a.christiani@medenus.de



Technical Inside Sales Department
MINDAUGAS PECKAITIS

Phone: +49 (0) 2761 / 82788-23
Mail: m.peckaitis@medenus.de



Head of Sales & Marketing
FRANZ FEICHTNER

Phone: +49 (0) 2761 / 82788-26
Mobile phone: +49 (0) 151 / 51002711
Mail: f.feichtner@medenus.de



Inside Sales Department
SEBASTIAN HUCKESTEIN

Phone: +49 (0) 2761 / 82788-11
Mail: s.huckestein@medenus.de



Head of Inside Sales Department
MANUEL SCHEPP

Phone: +49 (0) 2761 / 82788-20
Mobile phone: +49 (0) 170 / 6355309
Mail: m.schepp@medenus.de



Inside Sales Department
STEFANIE MÜLLER

Phone: +49 (0) 2761 / 82788-13
Mail: s.mueller@medenus.de



If you want to know more about solutions from MEDENUS for the gas industry, please contact your local contact person or go to our internet site at www.medenus.de

Trade representation worldwide
medenus.de/de/kontakt.html

MEDENUS
Gas-Druckregeltechnik GmbH

Im Langen Feld 3
D-57462 Olpe
Phone: +49 (0)2761 82788-0
Fax: +49 (0)2761 82788-9
Mail: info@medenus.de
Internet: www.medenus.de



THE MEDENUS PLUS

10 reasons for good business relations

1. Consultancy expertise and quality standards developed over decades
2. Broad and proven standard range of feedback controllers
3. Modern, fast and efficient production for series products and for individual orders
4. Customer-specific design of pressure regulators and vacuum regulators and special designs
5. Guaranteed deadline compliance with a delivery deadline guarantee
6. Fast response time in all matters
7. Sufficiently large parts storage for production and spare parts
8. Customer-specific theory & practice training courses
9. Modular design right across the entire product range to facilitate optimized handling of spare parts
10. 100% Made in Germany

Notes

A series of horizontal dotted lines for writing notes.

In the download area of our homepage, this document is available in different languages. You can use the following QR codes and links to go directly to this document in your language.



Deutsch:

http://medenus.de/files/upload/downloads/S100/Pi_S100_de.pdf



English:

http://medenus.de/files/upload/downloads/S100/Pi_S100_en.pdf



MEDENUS Gas-Druckregeltechnik GmbH

Phone +49 (0)2761 82788-0

Fax +49 (0)2761 82788-9

Im Langen Feld 3 / D-57462 Olpe

info@medenus.de

www.medenus.de

EN